

Metering Ball Valves



PVC

PP

SERIES: SM2

SIZES: 1/2" – 1"

ENDS: Threaded, Socket, Butt¹ or ChemFlare™²

SEATS: PTFE

O-RINGS: EPDM, FPM (Viton®)



Integral 180° Scale with 5° Increments

- Linear flow control and settable flow rates

Chemline **SM2 Series** Metering Ball Valve is designed for fine linear flow control of chemicals or clean fluids. The ball is solid with graduated V-groove cut on the outside surface. Precise linear flow control is accomplished through 180° rotation of the handle. With a positioning electric actuator, this becomes an inexpensive control valve. If higher C_v values are required, refer to SP Series Proportional ball valves.

Features

Precise Linear Flow Control

- Provided by a special V-groove ball and wide handle travel (0° to 180°)

High End Ball Valve Features

- Full Blocking design
- Double Stem O-Rings for safety
- PTFE seats with elastomer cushion
 - Automatically compensates for seat wear or expansion
- 230 psi pressure rated (PVC)

Low Stem Torques

- Due to floating ball design and cushioned PTFE seats

Bidirectional

- Works with flow in either direction

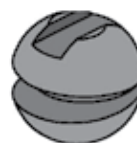

Ball Detail



¹Butt ends for fusion to Chemline metric PP piping
²For ChemFlare™ end connectors, consult Chemline

SM2 Series Metering Ball Valves

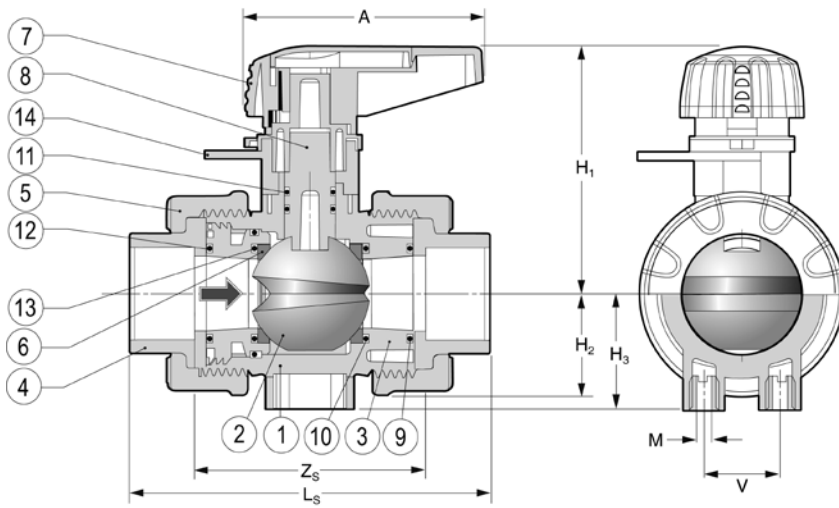

PARTS

No.	Part	Pcs.	Materials
1	Body	1	PVC, PP, PVDF
2	Ball	1	PVC, PP, PVDF
3	Carrier	1	PVC, PP, PVDF
4	End Connector	2	PVC, PP, PVDF
5	Union Nut	5	PVC, PP, PVDF
6	Ball Seat	2	PTFE
7	Handle	1	PVC
8	Stem	1	PVC, PP, PVDF
9	Carrier Face O-Ring	1	EPDM, FPM(Viton®)
10	Carrier O-Ring	1	EPDM, FPM(Viton®)
11	Stem O-Ring ¹	2	EPDM, FPM(Viton®)
12	Face O-Ring	1	EPDM, FPM(Viton®)
13	Seat Cushion ¹	2	EPDM, FPM(Viton®)
14	Position Indicator Scale	1	PVC

DIMENSIONS INCHES

Size							PVC			PP		
	A	H ₁	H ₃	H	M	V	Z _s	L _s	H ₂	Z _s	L _s	H ₂
1/2"	2.62	2.48	1.10	2.50	M5	0.98	2.48	3.74	0.99	2.64	3.74	1.06
3/4"	3.21	3.03	1.20	2.70	M5	0.98	2.83	4.33	1.16	3.03	4.29	1.18
1"	3.21	3.39	1.60	3.00	M6	1.02	3.11	4.84	1.39	3.27	4.69	1.57

ELECTRICALLY OR PNEUMATICALLY ACTUATED

The metering ball valve becomes a proportional control valve with the addition of an E Series electric or PG Series pneumatic actuator with 4-20 mA positioner

- Thermoplastic housing and mounting bracket
- Manual override
- Position indication
- Mechanical travel stops
- Different voltages are available



E Series Electric



PG Series Pneumatic

E Series Electric Actuator on a SM2 Valve

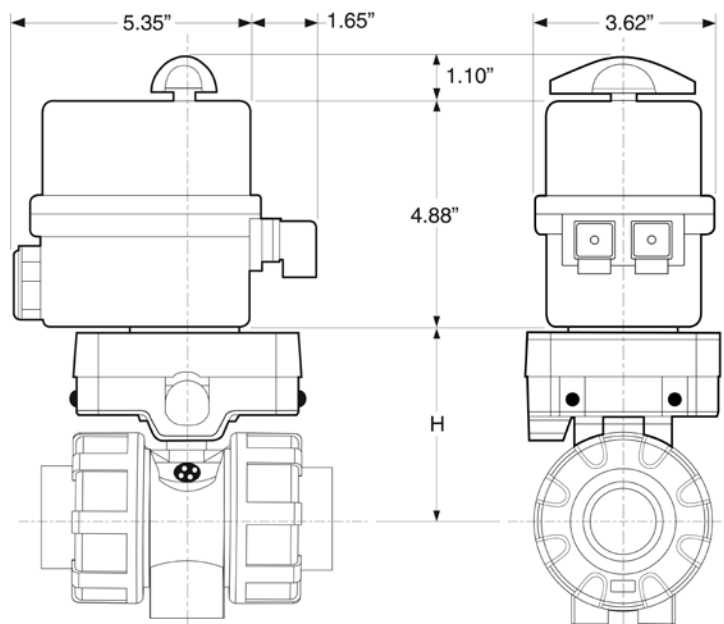

Side View

Port View

SM2 Series Metering Ball Valves



WORKING PRESSURES PSI

NET WEIGHTS LB. Cv VALUES

Size	PVC			PP				PVC	PP	USGPM Flow at 1 psi ΔP
	20°C 68°F	40°C 104°F	60°C 140°F	20°C 68°F	40°C 104°F	60°C 140°F	80°C 176°F			
1/2"	230	130	30	150	100	65	20	0.35	0.29	1.4
3/4"	230	130	30	150	100	65	20	0.60	0.44	1.9
1"	230	130	30	150	100	65	20	0.84	0.64	2.3

Temperature Ranges: PVC 0 to 60°C (32 to 140°F), PP 0 to 95°C (32 to 203°F)

Cv VALUE vs. VALVE OPENING

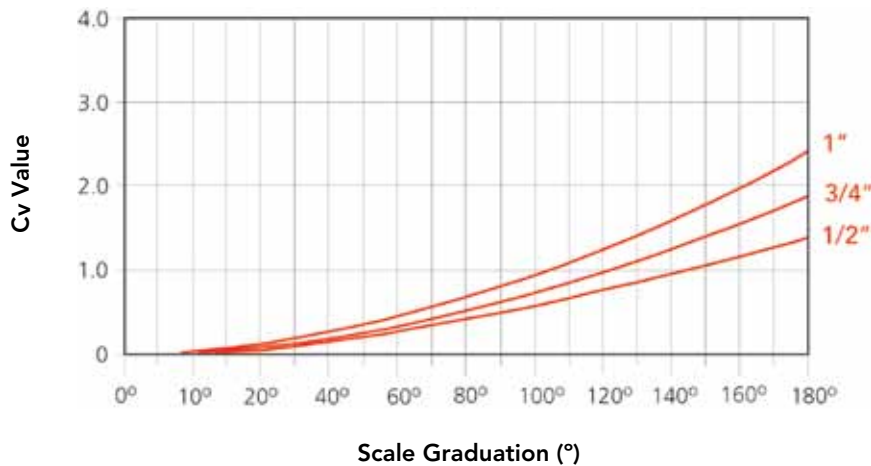

SAMPLE SPECIFICATION

1. All low flow control valves, 1/2" to 1", will be Chemline SM Series metering ball valves.
2. Body material will be PVC or PP, and o-rings will be EPDM or FPM (Viton®).
3. Body will be full blocking design with double stem o-rings for safety, rated at 230 psi maximum working pressure for PVC and 150 psi for PP material.
4. Ball will be floating design, molded solid with a V-groove for linear flow control over a 180° range of handle rotation.
5. Seats will be PTFE with elastomer cushions for positive closure with minimum stem torques and automatic compensation for seat wear and expansion.
6. Position indicating scale will be 0° to 180° with 5° increments for fine flow control and settable flow rates.
7. End connections will be 1/2" to 1" ANSI socket or FNPT threaded or 150 lb flanged or butt fusion for Chemline metric PP pipe or ChemFlare™ for PFA tubing.

ORDERING EXAMPLE

Chemline Metering Ball Valves			SM2	A	010	E	S
Valve Material	A – PVC	B – PP					
Size	005 – 1/2"	007 – 3/4"	010 – 1"				
Seals	E – EPDM	V – FPM (Viton®)					
Ends	S – Socket	T – Threaded	B – Butt ¹	CF – ChemFlare™			

Example: SM2 Series Ball Valve, PVC, 1", EPDM seals, socket ends.

¹ PP metric butt fusion ends (1/2" to 2") connect to Chemline PP piping systems.

VACUUM RATING

- 29.9 inches mercury

OPTIONS & ACCESSORIES

- **Reduced Ends**
- **Electric or Pneumatic Actuator with Positioner**
– Operates as a linear control valve